

SILVA 1-2-3

I know my position on the map. How do I go to a lake in the forest that I see on the map?

The easiest way to set a course towards the lake is with a simple and safe system used by expeditions, youth organisations, mountain guides, armies, orienteers and other navigators the world over: the Silva 1-2-3 System®

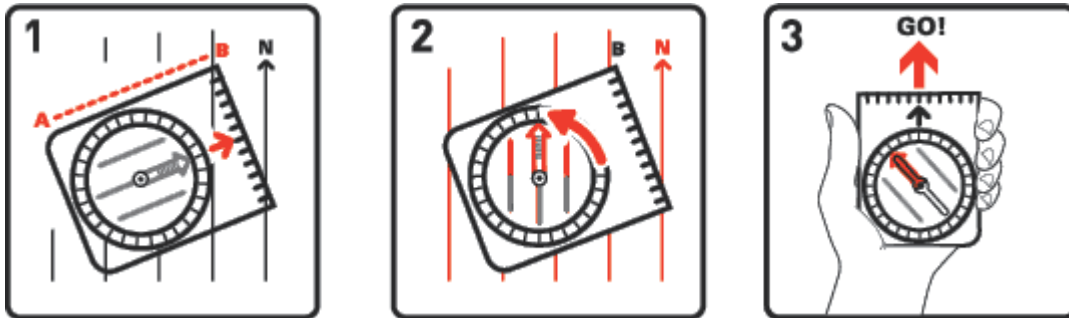

1. Place the compass on the map with the edge of the compass along the desired line of travel. Make sure Direction of Travel arrow points towards your destination.
2. Rotate the compass housing until N on the dial points North on the map. Check that the compass housing red/black North/South lines are parallel with the map's meridians.
3. Hold the compass in hand and turn your body until the red end of the compass needle (North) coincides with the red arrow in the bottom of the compass housing. The front of the compass with the direction of travel arrow is now pointing towards your destination.

NOTE: Keep in mind that magnetic variation may occur in the area that you are using your compass and this needs to be compensated for.

NOTE: If using a mirror-sighting compass: angle the mirror/lid approximately 45 degrees towards yourself and hold with straight arm out in front of you. Now, while looking in the mirror to see that the needle aligns with the red/black N/S arrow, sight above the mirror (using the sight) towards an object in the field in line with the direction of travel.